

NOTICE - PROPRIETARY INFORMATION
 THE DESIGN AND RELATED INFORMATION CONTAINED HEREIN IS THE SOLE PROPERTY OF NUTFIELD TECHNOLOGY, INC. THE DISCLOSURE OF THIS INFORMATION DOES NOT CONSTITUTE THE RELEASE OF ANY PROPRIETARY RIGHTS THEREIN. PERMISSION TO REPRODUCE THIS INFORMATION OR THE PRODUCTS DISCLOSED HEREIN MUST BE OBTAINED IN WRITING FROM NUTFIELD TECHNOLOGY, INC.

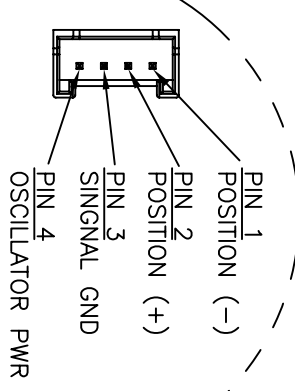

POSITION DETECTOR
 CONNECTOR: MOLEX 35363-0410
 MATING CONNECTOR: MOLEX 35507-0400
 TERMINALS: MOLEX 50212-8000 (REEL)
 MOLEX 50212-8100 (LOOSE)
 (24-30 AWG)

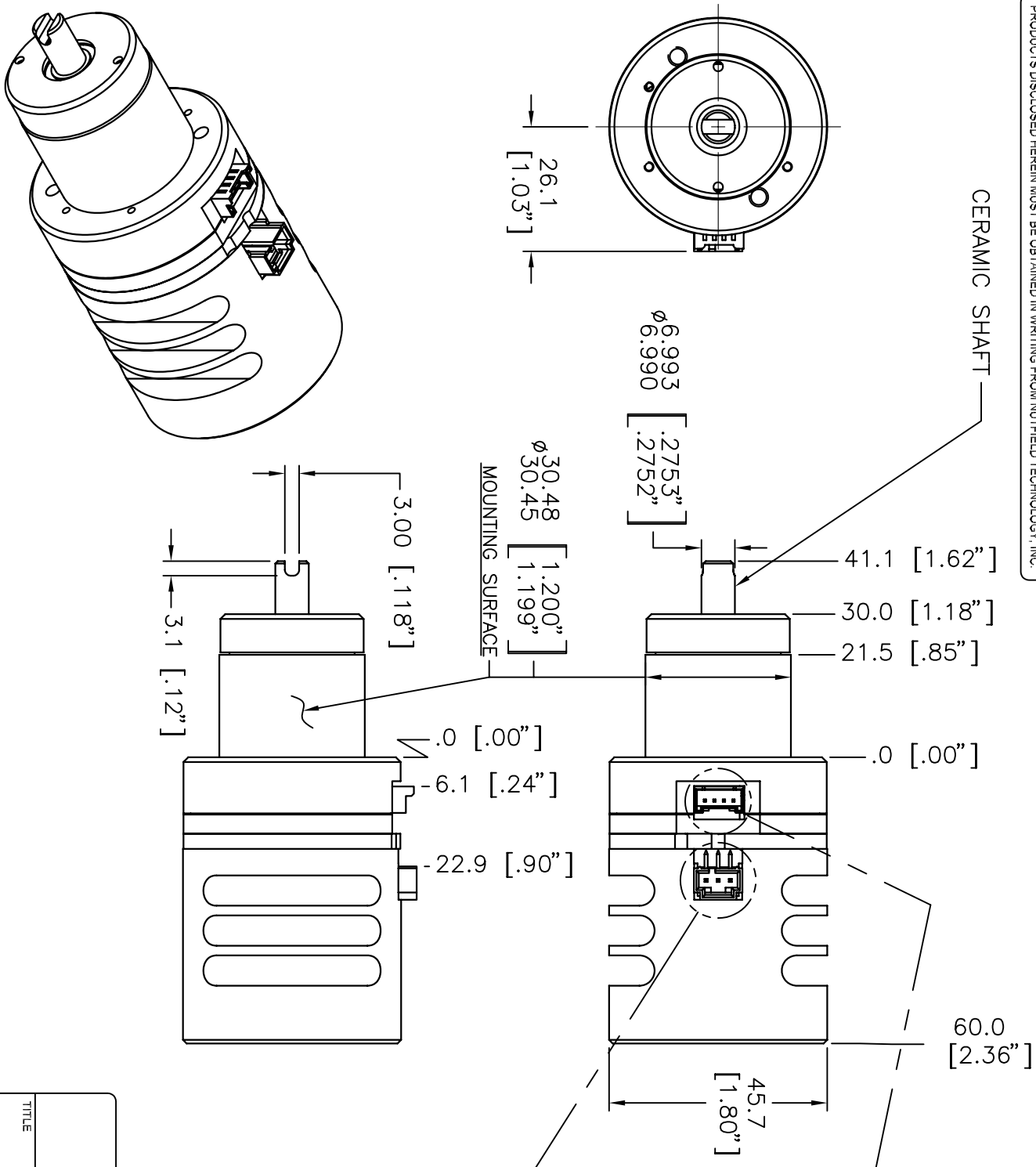
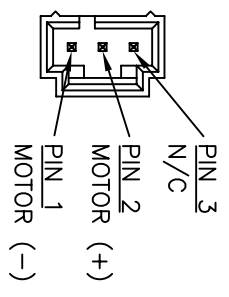

MOTOR CONNECTOR
 CONNECTOR: MOLEX 70553-0002
 MATING CONNECTOR: MOLEX 50-57-9403
 TERMINALS: MOLEX 16-02-0082 (REEL)
 MOLEX 16-02-0097 (LOOSE)
 (24-30 AWG)

TITLE		NUTFIELD TECHNOLOGY, INC.			
49 RANGE ROAD, WINDHAM, NH 03087		TEL: 603.893.6200 FAX: 603.893.6214			
QUANTUMSCAN-30		OUTLINE			
SIZE	SHEET	DRAWN BY	DATE	DWG. NO.	REV
A	1 OF 1	JDG	5/14/02	82-0004	A