

# ProMaster TechSpec

Operating Wavelength	248nm standard, 193nm option
Energy density on target	0.5-5J/cm <sup>2</sup> , manual setting of energy density, with graduated rotation control on BDU side. Additional internal condensor lenses (inverse BET) allow setting up for user definition of e.d. range, with trade-off for process area.
Rep.rate	0-300Hz, controlled by ProcessPower s/w(500Hz option available)
Feature size	Up to 250 $\mu$ m, determined by mask, OR write in X,Y using selected motifs
Standard mask changer	linear motorized 32-position motif selector, standard mask includes a range of circles, squares and stripes. User-determined mask plates can also be fitted
Intelligent aperture	A motorized rectangular aperture(MRA) is used in conjunction with the linear mask selector to create an infinite number of combination motifs, stored in system memory for later recall.
Machining Resolution	<1.5 $\mu$ m, 3e-248 lens, fixed demag. 10:1 configuration.
Part Vision	TTL image is presented in window on flat screen monitor. Full screen mag. 400X, features include electronic zoom on selected areas, video measuring cursor, o/p to printer etc.
Lighting	co-axial
Shield Gas/Fume Extraction	Integrate co-axial nozzle provides He atmosphere with efficient fume extraction to external blower.
Part Holder	100mm dia. vacuum stage
Theta Axis	360° continuous rotation & micrometer driven manual stage
Z-Focus	Manual 20mm.
Part Motion	100mmx100mm.
Motion Resolution	1 $\mu$ m
Control System	Industrial PC running XP
ProcessPower s/w Control	Synchronization of laser firing with part motion and mask selection, accepts industry standard file formats, .dxf, Gerber, Exellon, ASCII

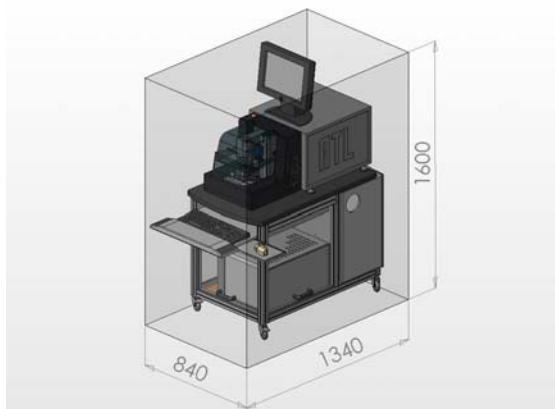

ProMaster turnkey workstation includes chariot with integrated gas cabinet and operator console.

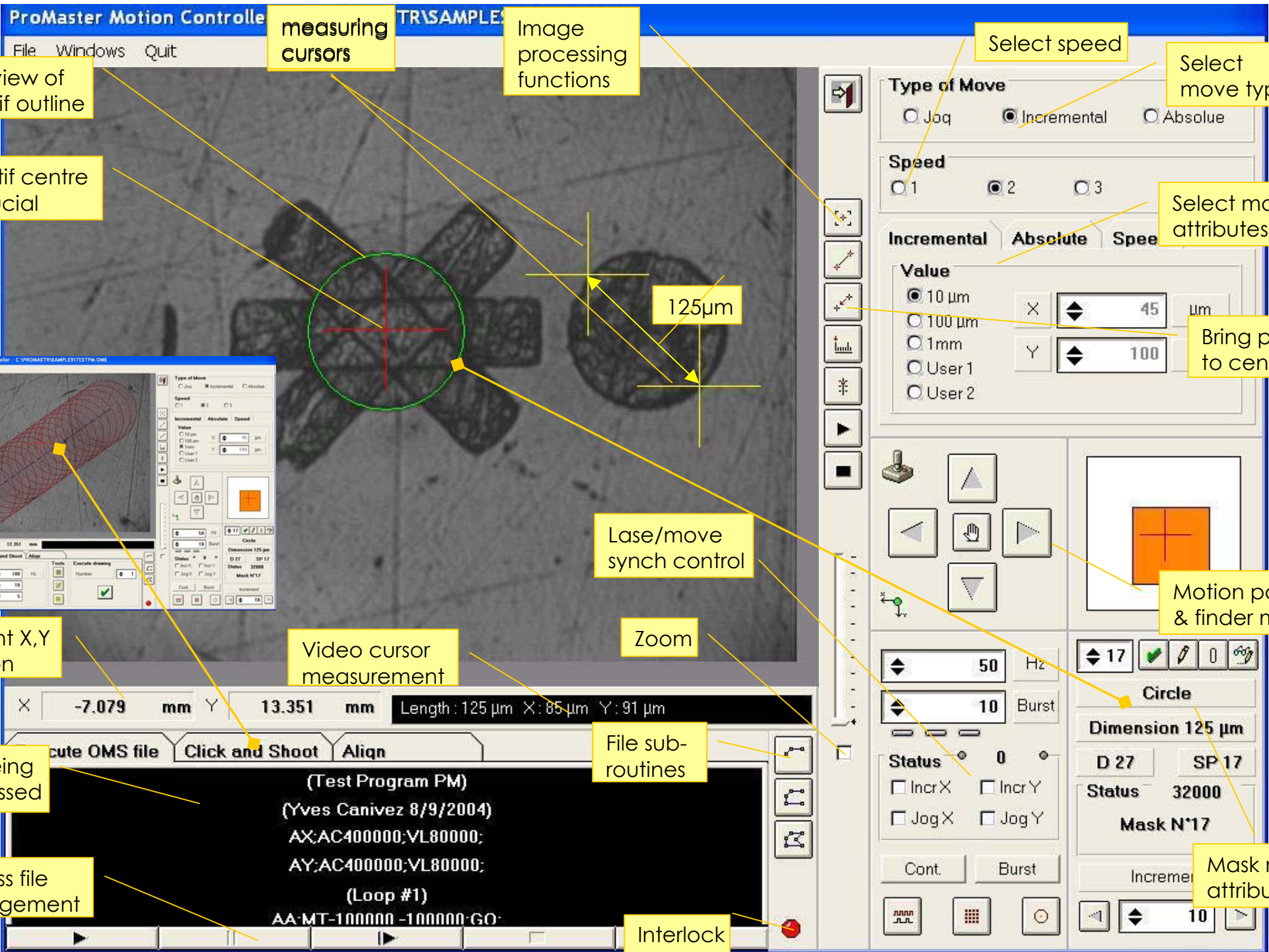

Preview of motif outline

Motif centre fiducial

measuring cursors

Image processing functions

Select speed

Select move type

Select move attributes

Bring point to centre

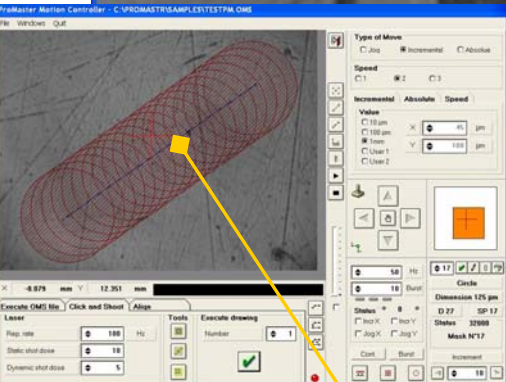

Current X,Y Position

Video cursor measurement

Lase/move synch control

Zoom

Motion pad & finder map

File being processed

Process file management

File sub-routines

Interlock status

Mask motif attributes