

FDM Helps Automotive-Products Supplier Streamline Design

"Spending a few thousand dollars on a prototype saves us months in engineering time."

- Bruce Vanisacker, Dana Corporation

Real Challenge

Dana Corporation, a Tier One automotive supplier, assumes responsibility for designing components to meet its customers' requirements. Validating these designs with prototypes from conventional machining and casting methods required weeks or months and tens of thousands of dollars. The time and expense limited Dana's use of prototypes.

Real Solution

"By the time a conventional prototype can be made, it's possible to invest large amounts of time and money in a design that doesn't work," says Bruce Vanisacker, designer for Dana's Rapid Prototyping/CAE Services. Contrasting fused deposition modeling (FDM) to conventional methods, he says, "FDM enables us to produce accurate and specialized functional rapid prototypes in a few days. A physical part gives everyone the opportunity to hold and touch and feel the part and determine exactly where we stand."

Dana's products include under-the-hood filtration systems, cooling systems, differential cases, carriers and housings. "It's often difficult to determine, just by looking at one of our complex assemblies on a computer screen, whether or not it meets key form and fit requirements," Vanisacker said. "But in the past, when we prototyped new concepts using conventional methods it took too long and was expensive." Seeking a better way, Dana investigated prototype technology options.

"We took a cross-section of parts from all of our divisions and sent them to five rapid prototyping system suppliers," Vanisacker said. "We decided that the Fortus system produced the best parts because it could produce highly accurate and much stronger parts in multiple colors. FDM is also very easy to use and quite economical."

Dana has found that its Fortus system excels at making accurate rapid prototypes of complicated assemblies like the clutch assembly shown. "During the design, we add colors to the components to make the most important ones stand out. Then we build the prototypes in the same colors," says Vanisacker. Dana also uses FDM for more

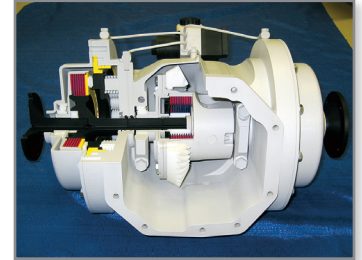

Image 1: The FDM prototype of an automotive clutch helped Dana identify and fix problems with the initial design concept.

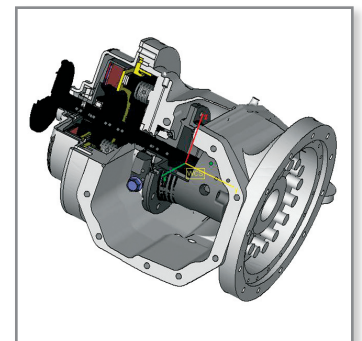

Image 2: Assembly CAD model.

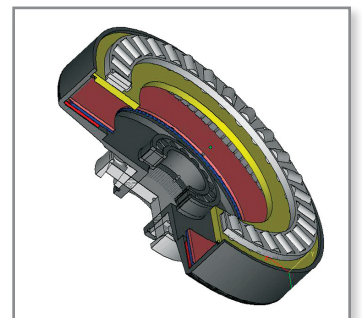

Image 3: Component CAD Model

than visualization. "FDM prototypes are so strong that in some cases we even use the prototypes to help evaluate the performance of the part."

This clutch prototype demonstrated that the initial design concept would not fit the application. Discovering this at an early stage in the design process kept Dana from spending additional time or money on the concept. It also provided a head start in moving towards a new design that did meet the customer's requirements.

"FDM rapid prototypes have become a regular part of our product development process because they take just a few days and about one-tenth the cost of conventional machining and casting methods," Vanisacker says. "Spending a few thousand dollars on a prototype saves us months in engineering time."

Award-winning model: Dana's rapid prototyping lab won highest honors from design industry peers for the featured clutch assembly at a recent FDM user group conference prototype competition.

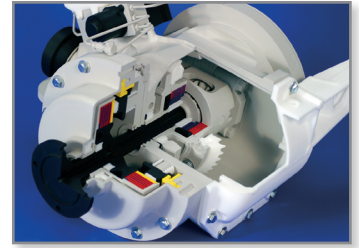

Image 4: Close-up view of clutch components.

For more information about Fortus systems, materials and applications, call **888.480.3548** or visit www.fortus.com

Fortus 3D Production Systems
Stratasys Incorporated
7665 Commerce Way
Eden Prairie, MN 55344
+1 888 480 3548 (US Toll Free)
+1 952 937 3000
+1 952 937 0070 (Fax)
www.stratasys.com
info@stratasys.com

Fortus 3D Production Systems
Stratasys GmbH
Weismüllerstrasse 27
60314 Frankfurt am Main
Germany
+49 69 420 994 30 (Tel)
+49 69 420 994 333 (Fax)
www.stratasys.com
europe@stratasys.com

©2009 Stratasys Inc. All rights reserved. Stratasys and FDM are registered trademarks and Fortus, Real Parts, Fortus 200mc, Fortus 360mc, Fortus 400mc, Fortus 900mc, Insight, Control Center and FDM TEAM are trademarks of Stratasys Inc., registered in the United States and other countries. *ULTEM 9085 is a trademark of SABIC Innovative Plastics IP BV. All other trademarks are the property of their respective owners. Product specifications subject to change without notice. Printed in the USA. AP-DANA 02/09

FORTUS[™]
3D PRODUCTION SYSTEMS