

Automotive-Filter Maker Tests PPSF Prototype on V8 Engine

“Vibration affects filter efficiency, so it was important to mount the prototype directly on the engine for accurate testing.”

- Russ Jensen, Parker Hannifin-Racor

Parker Hannifin’s Racor division recently designed an emissions filter that enables diesel engine manufacturers to meet new emission requirements. The company used its Fortus FDM system to create a PPSF (polyphenylsulfone) prototype of the filter. The filter, called a crankcase vapor coalescer, was used for functional design testing.

The PPSF prototype was durable enough to mount directly on the valve cover of a 6.0-liter V8 diesel engine and test at various loads for 78 hours. “The prototype filter collected blow-by gases containing 160°F (71°C) oil, fuel, soot, and other combustion by-products,” says Racor senior development engineer Russ Jensen. “It withstood the operating environment and heat of the engine.”

“Aside from some staining, the part appears to have the same strength and properties as when it was first assembled. We never saw a leak from this assembly, and we were very pleased with its performance.”

Racor was a Fortus beta-test site that helped prove out the capabilities of PPSF prior to its commercialization as a rapid prototyping material. Racor was interested in PPSF because it can handle heat near 400°F (204°C), it resists petroleum products, acids, and bases, and its strength is superior to other prototyping thermoplastics.

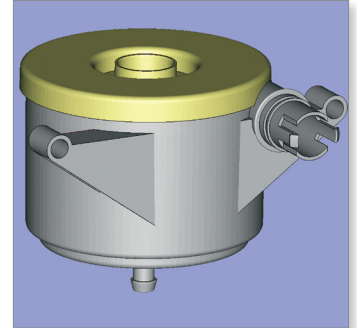

Image 1: CAD model of Parker Hannifin emissions filter.



Image 2: PPSF prototype mounted on V8 engine.

For more information about Fortus systems, materials and applications, call **888.480.3548** or visit www.fortus.com

Fortus 3D Production Systems
Stratasys Incorporated
7665 Commerce Way
Eden Prairie, MN 55344
+1 888 480 3548 (US Toll Free)
+1 952 937 3000
+1 952 937 0070 (Fax)
www.stratasys.com
info@stratasys.com

Fortus 3D Production Systems
Stratasys GmbH
Weismüllerstrasse 27
60314 Frankfurt am Main
Germany
+49 69 420 994 30 (Tel)
+49 69 420 994 333 (Fax)
www.stratasys.com
europe@stratasys.com

©2009 Stratasys Inc. All rights reserved. Stratasys and FDM are registered trademarks and Fortus, Real Parts, Fortus 200mc, Fortus 360mc, Fortus 400mc, Fortus 900mc, Insight, Control Center and FDM TEAM are trademarks of Stratasys Inc., registered in the United States and other countries. *ULTEM 9085 is a trademark of SABIC Innovative Plastics IP BV. All other trademarks are the property of their respective owners. Product specifications subject to change without notice. Printed in the USA. AP-PARKER 02/09

FORTUS[™]
3D PRODUCTION SYSTEMS