

Cobolt Dual Combiner

Preliminary DATA SHEET

A permanently aligned combination of any 2 wavelengths in a compact package

The Cobolt Dual Combiner is a unit which offers any combination of two 04-01 model lasers at any power level in a permanently aligned package. The extreme robustness of the 04-01 models and proprietary HTCure™ manufacturing technology allows Cobolt to offer the Dual Combiner with excellent beam overlap and beam pointing stability.

The Cobolt Dual Combiner is intended for use in a laboratory environment as a drop-in replacement to Ar⁺ & Kr⁺ gas lasers or for integration as OEM component module for use in demanding bio-analytical applications such as flow cytometry, laser scanning cytometry, DNA sequencing and confocal microscopy.

Specifications

Power level	10 mW – 300 mW
Spatial mode	TEM ₀₀ , M ² <1.1
Beam diameter at aperture	700 μm
Beam divergence (full angle)	<1.2 mrad
Noise, 10 Hz –2 MHz (pk-pk)	<3% , typical <2%
Noise, 10 Hz –2 MHz (rms)	<0.3% , typical <0.2%
Long-term stability (8 h)	<3% (± 1.5%)
Beam pointing stability (over 10–40 °C)	<25 μrad/°C
Beam overlap	<250 urad
Polarization ratio	>100:1 linear
Package dimensions (mm)	190 x 65 x 46
Operating temperature	10–40 °C

Suitable for combining 04-01 laser models 457nm–594nm

Cobolt Twist™ 457 nm
Cobolt Blues™ 473 nm
Cobolt Calypso™ 491 nm
Cobolt Fandango™ 515 nm
Cobolt Samba™ 532 nm
Cobolt Jive™ 561 nm
Cobolt Mambo™ 594 nm

Dimensions

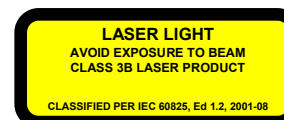
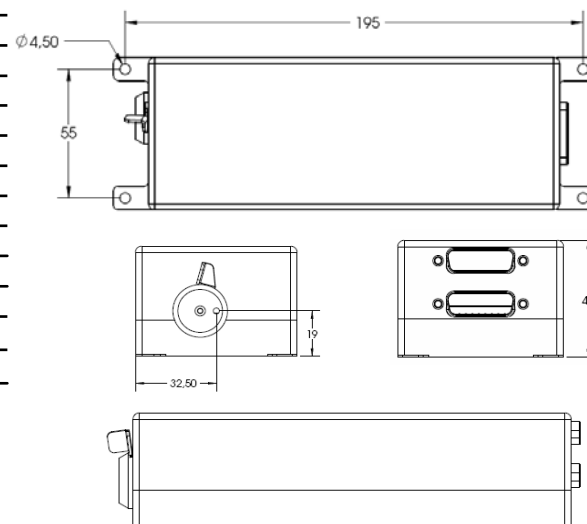

Issued 2009-09-01. Subject to change without notice.

Class 3B (IEC60825-1), IEC60950-1, UL 60950-1